

Space Charge and Aging in Polyethylene Cables

Thomas V. Prevenslik

Abstract— Space charge in the polyethylene (PE) insulation of high voltage power cables is generally thought caused by field induced injection of charge from electrodes. However, space charge is observed absent electrical fields, say as cables are wound on a drum for shipping. To explain this anomaly, van der Waals (vdW) bonds in the interstice between PE molecules are posited to break at low stress levels and form quantum electrodynamics (QED) cavities having EM resonances beyond the ultraviolet (UV) and vacuum ultraviolet (VUV). But the low frequency electromagnetic (EM) radiation released by the broken vdW bonds is suppressed in the VUV resonant QED cavities. Since the corresponding EM energy loss must be conserved, a burst of at least UV radiation is produced by the suppressed EM radiation undergoing frequency up-conversion to the VUV resonance of the QED cavities. The UV then scissions the PE molecules in the QED cavities leaving a space charge of radicals, typified here by CH⁺ fragments. Since the breaking of vdW bonds at low stress levels cannot be avoided, cable life is proposed extended by blocking the UV from the PE molecules, say by adding Tinuvin®, or the like, to the PE during the extrusion of the power cables.

I. INTRODUCTION

Space charge in PE insulation of high voltage power cables is generally [1] thought caused by the field induced injection of charge from electrodes. However, it was recently disclosed [2] space charge is produced without electrical fields by the scission of PE molecules at low stress levels, say as cables are wound on a drum for shipping. But what causes PE to scission at low stress levels?

The PE molecule is usually considered to scission only under high tensile stress. Computer simulations [3] suggest the tensile scission of PE molecules to occur ~ 4 eV, but experiments show 5-10 times lower ultimate strength. Indeed, the CH⁺ radical signatures found by electron paramagnetic resonance (EPR) during tensile tests [4] at stress levels less than 50 % of ultimate suggest another mechanism is operating at low stress levels to scission the PE molecules.

The PE molecule may scission at zero applied stress if irradiated [5] with UV radiation, and therefore a plausible explanation for the low ultimate found in experiments is photolysis from *internal* UV sources. UV blockers have been used to protect PE against *external* UV sources, but the literature is silent the addition of blockers to PE insulation to protect against *internal* UV sources.

In tensile tests, exposing the specimens to *external* UV sources is representative of *internal* UV sources. Indeed, 1 % of the UV stabilizer Tinuvin® 327 added to LDPE powder prior to compression molding showed [6] significant

improvement in mechanical properties during tensile testing after exposure to *external* sources of UV radiation.

Similarly, the scission of PE molecules from *internal* UV sources was simulated [4] by exposing bundles of micron-sized diameter PE filaments to an *external* UV source. Here the EPR spin-trap - Tinuvin®770 - was applied as a coating to the filaments by soaking the bundles in 1% wt dichloromethane solution. Although CH⁺ radicals were detected during tensile testing, no EPR signal was observed after washing the filaments. This suggests the Tinuvin®770 blocked the *external* UV from the filaments, thereby supporting the argument that adding Tinuvin®, or the like, to the PE in the extrusion process will tend to block any *internal* UV produced during the life of the PE.

In this paper, PE scission is proposed caused by photolytic scission under UV radiation, the UV produced as vdW bonds break in submicron QED cavities. The process producing the UV is called cavity QED induced EM radiation applicable where photons and electrons are found at ambient temperature including: flow electrification [7], Casimir effect [8], and ultrasonic ionization [9].

II. BACKGROUND

Consistent with vdW bonds providing the weak link for deformation or fracture, photolytic scission of PE molecules is proposed initiated by the breaking of vdW bonds in submicron QED cavities at energies < 0.1 eV. The QED cavities have EM resonances beyond the VUV, and therefore the low frequency EM radiation released by the broken vdW bonds is by definition suppressed. But the EM energy loss in suppressed EM radiation may only be conserved by an equivalent gain at the resonant VUV frequency of the QED cavity. In this way, *internal* UV radiation is produced to scission the PE molecules at low stress levels.

Usually, the EM radiation released by a number of vdW bonds is incoherent, and therefore cannot collectively combine to reach the ~ 4 eV level necessary to scission the PE molecules. However, the interstice as a QED cavity *makes* the collective EM radiation released by the breaking of vdW bonds coherent. This means the breaking of vdW bonds in the interstice at low stress levels produces a burst of coherent VUV radiation sufficient to scission the PE molecules. Thus, scission of the PE molecules not only produces a space charge typified by CH⁺ radicals, but also nucleates and grows the submicron cavities. Indeed, aging of PE insulation over the life of the cable may be quantified by the observed number and size of cavities.

Since the breaking of vdW bonds at low stress levels cannot be avoided, this paper suggests the life of the power cable may only be extended by blocking the *internal* UV radiation from the PE molecules; say by adding chemical blockers to the PE during the extrusion process.

III. QED CAVITY

Cavity QED induced EM radiation is usually applied to stationary cavities embedded in a liquid or solid medium. But in PE the QED cavities at the submicron level form abruptly as vdW bonds break at low stress levels. Figure 1 shows the QED cavity typical of a “penny” crack prior to forming, the load transferred across the crack faces by vdW bonds in parallel with PE molecules. The QED cavity representing the crack is a thin cylindrical volume of radius R and height d having an EM resonance in the VUV.

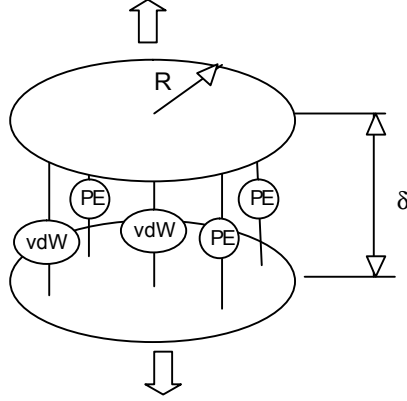

Figure 1 QED Cavity in PE prior to formation

The QED process of producing space charge and submicron cavities is depicted in figure 2. (a) The QED cavity resonant at VUV frequencies suppresses EM radiation released by the breaking of vdW bonds, the subsequent EM energy loss conserved by producing EM radiation at the VUV resonant frequency of the QED cavity. (b) By photolysis, the UV radiation produced scissions at least one PE molecule to form a CH^+ fragment. (c) The CH^+ fragment [2] comprises highly reactive primary end radicals ($-CH_2 - C^*H_2$) that by chemical chain reaction [10] propagates over the remaining PE molecules leaving a space charge of CH^+ fragments and a submicron cavity.

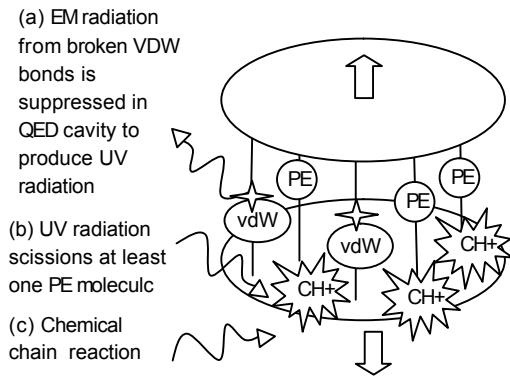

Figure 2 QED Process of Space Charge and Submicron Cavity Formation

Although the PE molecule scissions under high tensile stress, scission in a QED cavity occurs by photolysis at low stress levels. The QED theory of how this occurs is described as follows.

IV. THEORY

The total EM energy U suppressed from the breaking of vdW bonds is,

$$U = NE_{vdW} \quad (1)$$

where, N is the number of vdW bonds that break in the QED cavity, and E_{vdW} is the EM energy released in breaking a single bond. For PE, $E_{vdW} \sim 0.1$ eV [11]. Since the QED cavities are VUV resonant, the conservation of EM energy is,

$$U = N_{VUV}E_{VUV} = NE_{vdW} \quad (2)$$

where, E_{VUV} is the Planck energy of the VUV photons and N_{VUV} is their number,

$$E_{VUV} = \frac{hc}{2(d + 2e_p)} \quad \text{and} \quad N_{VUV} = \frac{NE_{vdW}}{E_{VUV}} \quad (3)$$

where, h is Planck's constant, c is the speed of light, and e_p is the penetration depth of VUV radiation, say $e_p \sim 10$ nm.

Assuming a close packing of PE molecules in the circular surfaces, the number N of vdW bonds depends on the C-C spacing D along the PE molecule chain, $D = 0.154$ nm.

$$N = p \left(\frac{R}{D} \right)^2 \quad (4)$$

Combining,

$$N_{VUV} = p \left(\frac{R}{D} \right)^2 \frac{E_{VDW}}{E_{VUV}} \quad (5)$$

Upon loading, QED cavity of radius R evolves into a 3D ellipsoid growing under repetitive loading by increments DR . Assuming the cavity to grow to radius R in a single load application, the number N_{VUV} of VUV photons having Planck energy E_{VUV} is shown in figure 3.

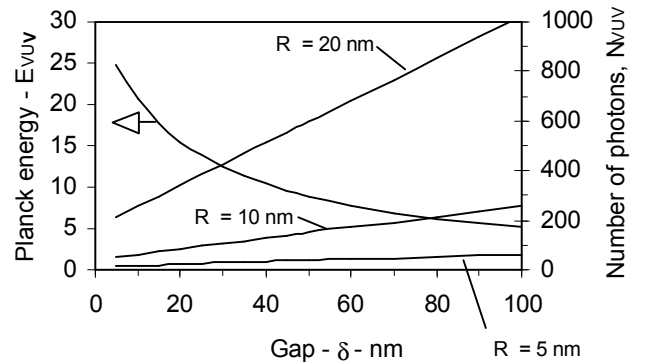

Figure 3 Planck energy E_{VUV} and number N_{VUV} of Photons

The number N_{CH^+} of CH^+ charged fragments depends on the scission quantum yield Y of PE, i.e., $N_{CH^+} = YN_{VUV}$. The PE yield in the UV is not known, but taking the yield [12] of poly methyl methacrylate (PMMA) as representative of PE, $Y \sim 0.03$ to 0.04 for UV from 214 to 229 nm, or $E_{VUV} \sim 5$ eV. Figure 3 shows $E_{VUV} > 5$ eV for all $d < 100$ nm. For $R = 5, 10,$ and 20 nm, $N_{VUV} \sim 64, 256,$ and 1023 , and therefore $N_{CH^+} \sim 2, 9,$ and 36 . Thus, to produce at least one CH^+ fragment necessary to initiate the chemical chain reaction, $R > 5$ nm.

V. DISCUSSION

Cavity QED induced EM radiation is a new way to describe the aging of PE insulation in power cables which can be understood by comparisons with molecular and space charge models. Fundamental in these comparisons are differences in how submicron cavities are related to space charge. Clearly, space charges in later stages of cable life are charges injected from the electrodes [1] into existing cavities in the PE. In this interpretation, space charges [13] are consequence of aging. To wit,

“It is our contention that space charges are a consequence of aging, i.e., charges are injected only when physical defects (such as microcavities) have been formed by the field-induced strain...space charges are related to the formation of submicrocavities, and therefore, are a consequence, not a cause of high field aging.”

However, space charges are produced in PE early in life absent field-induced strain and charge injection, e.g., the 0.25 Cm^{-3} residual charges [13] always observed in PE. To explain this anomaly, QED induced space charge was proposed [2] as the mechanism by which charge is produced at the instant submicron cavities form in PE under mechanical loads.

More recently, a Molecular theory [14] was proposed that closely mirrors the QED induced space charge theory. Aging is explained by a series arrangement of double energy barriers based on distinct physical mechanisms, the first of which is the formation of nano cavities (breaking of vdW bonds), and the second is the deformation of molecular segments (scission of PE molecules).

Experimental support for the breaking of vdW bonds being distinct from the scission of the PE molecule finds basis [14] in the PE lifetime t under field F given by,

$$t = (h/kT) \exp\left\{\left(\frac{DG - [1/2e(DV/2)F^2]}{kT}\right)\right\} \quad (6)$$

where, DG is Gibb's free energy representing the barrier height, k is Boltzmann's constant, T is absolute temperature, e is the permittivity, and DV is the strained volume. A plot of F^2 vs. $\log t$ of representative PE experimental data [1] is reproduced here in figure 4.

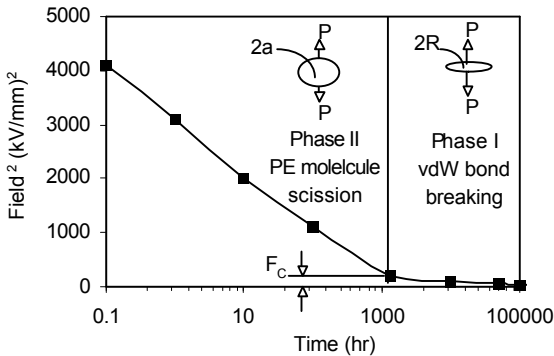

Figure 4 Molecular double barrier and QED theories

Clearly, the slope representing the strained volume DV abruptly changes at a critical field F_c , thereby supporting the argument that distinctly different mechanisms characterize the lifetime of PE under stress.

However, this does not necessarily support the strained volume as the correct parameter deduced from the slope of the F^2 vs. $\log t$ plot. It is well known [13] that sample sizes require very different DV values to fit experimental data. Indeed, the morphology of the PE samples is generally thought important in predictive life estimates based on strained volume, but current aging theories lack a theoretical basis from which morphology could be included in lifetime predictions. Instead, PE morphology is included after the fact through the vague notion of strained volume to fit the experimental data.

Unlike current aging theories, the QED theory is logically based on PE morphology depicted by Phase I and II in figure 4. In Phase I, vdW bonds break to form a submicron cavity of width $2R$ and height d , while in Phase II, PE molecules scission to form micron cavities of width $2a$ and height $2b$. Phase I is described by QED theory, but Phase II may be more than adequately described by conventional crack growth formalism. This does not mean the breaking of vdW bonds and formation of CH^+ fragments only occurs in Phase I, as vdW bonds certainly are broken in the crack tip during Phase II.

In Phase II, conventional crack growth [15] formalism in PE gives the crack growth rate da/dt by the power law,

$$\frac{da}{dt} = B'K_1^A(1 + R_L)^{-6} \quad (7)$$

where, $B' = 0.4$ for HDPE at ambient temperature, and R_L is the ratio of minimum to maximum load. For creep, $R_L = 1$, and for fatigue $R_L = 0$.

The stress intensity factor K_1 depends on the cavity geometry. For a central loaded cavity of width $2a$ shown in Phase II of figure 4.

$$K_1 = P\sqrt{\pi a} \quad (8)$$

where, P is the Maxwell pressure,

$$P = 1/2e_0eF^2 \quad (9)$$

For fatigue with $R_L = 0$, PE follows the Paris relation,

$$\frac{da}{dt} = ADK^{4\pm 0.5} \quad (10)$$

where, DK_1 is the range in stress intensity, and $A = B'$ is the material constant.

Features of the QED cavity theory in explaining other anomalies in the aging of PE are discussed as follows.

A. Space charge models

The space charge models [1] claim PE aging is caused by charges, but have difficulty in explaining [13] why breakdown under AC fields occurs at lower fields than under DC, although the charges remaining in the dielectric under the AC field are 100 x less than under the DC field.

In the QED theory, space charge is produced by different mechanisms. In Phase I, CH^+ fragments are produced as the PE molecules scission by chemical chain reaction initiated by UV radiation produced in the nucleation of submicron cavities. In Phase II, the CH^+ fragments form by tensile scission of the PE molecules in micron resonant cavities.

Because of the cyclic Maxwell pressure in PE under AC fields, Phase II is marked by rapid growth of cavities beyond micron sizes compared to that for the slower growth under DC fields. In PE, fatigue growth [15] to reach creep growth levels similar to steady DC fields required 3 orders of magnitude less time. Thus, breakdown under AC fields occurs far faster than under DC fields.

Moreover, the residual charge under AC fields should also be less than for DC fields. To be sure, both Phases I and II produce space charge, but space charge and breakdown are not the same. Irrespective of whether the field is AC or DC, breakdown occurs because of the large cavities produced during Phase II. Since Phase I cavity growth under AC fields may be 3 orders of magnitude shorter than under DC, the charge remaining in the dielectric under AC fields may be expected to be 100x lower than that for DC fields.

B. Sample Size

The size of PE test samples is known [14] to have a significant effect on electrical breakdown, but no model takes this parameter into account.

In the QED theory, the size of the PE test samples is not explicitly included anymore than in fracture mechanics of more conventional solid materials. This is so, because QED theory similar to fracture mechanics treats every application separately depending on the size of the specimen.

Indeed, the observation that the electrical breakdown [17] of dielectrics may increase as with a decrease in sample thickness is not surprising if viewed from the standpoint of fracture mechanics where smaller specimens are invariably tougher in fracture than larger ones.

Moreover, the size effects in strained volume DV found in F^2 vs. $\log t$ plots [14] is proof positive the morphology of the PE is the controlling factor in lifetime of PE insulation, but morphology is not a design parameter in any of the current aging theories. In this regard, QED theory based on size dependent fracture mechanics and the breaking of vdW bonds may be a more appropriate as an aging theory.

C. Double Barriers

The Molecular theory of double barriers [14] proposed to explain the electrical aging of polymer is also applicable to mechanical and thermal aging. The lower barrier is associated with nano cavity deformation and the higher with the molecular segment deformation. The Molecular theory asserts small deformation of the nano cavity causes large deformations of the molecular segments by a 'lever' effect.

Generally, QED theory mirrors the double barriers in the Molecular theory. In Phase I, breaking of vdW bonds in submicron cavities corresponds to nano cavity deformation, while Phase II comprising scission of PE molecules corresponds to deformations of molecular segments.

However, the QED theory differs from the Molecular theory in that small deformations in the nano cavity do not cause large molecular deformations absent a mechanism to do so. The QED theory relies on the suppression of vdW bond energy to produce the UV radiation necessary to scission at least one PE molecule, the scission forming CH⁺ fragments that by a chain of chemical reactions scissions the remaining

PE molecules. In this sense, the 'lever' effect causes small deformations in the nano cavity (breaking of vdW bonds) to form the large deformation (scission of PE molecules). Absent an equivalent mechanism, however, the 'lever' effect appears unlikely do so because small deformations in forming nano cavities can only produce small deformations of molecular segments – not large deformations.

VI. CONCLUSION

A QED theory is proposed that PE molecules scission by photolysis from UV radiation produced in submicron cavities, and therefore the UV blocker Tinuvin®, or the like, is proposed added to PE in the extrusion process to extend cable life. Confirmatory EPR tests are pending.

ACKNOWLEDGMENT

Author acknowledges the advanced draft of the Molecular theory of double barriers by J-P Crine that provided the basis from which the QED theory is presented.

REFERENCES

- [1] G. Mazzanti, G. C. Montanari, and L. A. Dissado, "Electrical Aging and Life Models: The Role of Space Charge," *Trans. DEI*, vol. 12, pp. 876-90, 2005.
- [2] T. Prevenslik, "Space charge in submicron cavities by quantum electrodynamics?" presented at IEEE CEIDP, Nashville, October 16-19, 2005.
- [3] J. C. L. Hageman, G. A. de Wijs, R. A. de Groot, and R. J. Meier, "Bond Scission in a Perfect Polyethylene Chain and the Consequences for the Ultimate Strength," *Macromolecules*, Vol. 33, pp. 9098-108, 2000.
- [4] D. Wag, A. A. K. Klaassen, G. E. Janssen, E. de Boer, and R. J. Meier, "The detection of radicals in strained, high-modulus polyethylene fibres," *Polymer*, Vol. 36, pp. 4193-96, 1995.
- [5] R. H. Partridge, "Vacuum-Ultraviolet Absorption Spectrum of Polyethylene," *J. Chem. Phys.*, Vol. 45, pp. 1685-90, 1966.
- [6] J. Miltz and M. Markis, "The Effect of Ultraviolet Radiation on Chemically Crosslinked Low-Density Polyethylene," *J. Appl. Polymer Science*, Vol. 20, pp. 1627-33, 1976.
- [7] T. Prevenslik, "The Casimir force and the conservation of energy," presented at 10th National Congress on Theoretical and Applied Mechanics, 13-16 September, Varna, 2005.
- [8] T. Prevenslik, "The QED Electrical Double Layer in Flow Electrification," presented at 10th National Congress on Theoretical and Applied Mechanics, 13-16 September, Varna, 2005.
- [9] T. Prevenslik, "Ultrasonic Ionization Spectroscopy, presented at The 9th Western Pacific Acoustics Conference, Seoul, June 26-28, 2006.
- [10] S. N. Zhurkov, V. A. Zakrevskiy, V. E. Korshukov, V. S. Kuksenko, "Mechanism of Submicrocrack Generation in Stressed Polymers," *J. Polym. Sci.*, Vol. 10, pp. 1509-20, 1972.
- [11] G. C. Montanari, "A comparative investigation of electrothermal endurance models for insulating materials and systems characterization," *IEEE - Electrical Insulation Magazine*, Vol. 13, pp. 13-25, 1997
- [12] A. R. Shultz, P. Frank, B. F. Griffing, A. L. Young, "Quantum Yield for Poly(methyl methacrylate) Chain Scission by 214-239 nm Wavelength Light," *J. Polym. Sci. Polym. Phys. Ed.* Vol. 23, pp. 1749-1758, 1985.
- [13] J-P Crine, "Aging and Polarization Phenomena in PE under High Electric Fields," *IEEE Trans. DEI*, Vol. 9, pp. 697-703, 2002.
- [14] J-P Crine, "A Molecular Approach to the Electrical Ageing of Dielectric Polymers," to be published, 2006.
- [15] M. Parsons, E. V. Stepanov, A. Hiltner, E. Baer, "Correlation of fatigue and creep slow crack growth in a medium density polyethylene pipe material," *Journal of Materials Science*, Vol. 35, pp.2659-2674, 2000.
- [16] J-P Crine "On the Interpretation of some Electrical Ageing and Relaxation Phenomena in Solid Dielectrics," *IEEE Trans. DEI*, Vol. 12, pp. 1089-1107, 2005
- [17] V. K. Agarwal, V. K. Srivastava, "Thickness Dependence of Breakdown Field in Thin Films," *Thin Solid Films*, Vol. 8, pp. 377-81, 1971.